

DATA SHEET

TEA6330T

**Sound fader control circuit
for car radios**

Preliminary specification
Supersedes data of June 1991
File under Integrated Circuits, IC01

January 1992

Sound fader control circuit for car radios

TEA6330T

FEATURES

- Stereo/hi-fi processor for car radios performed with volume, balance, bass and treble controls
- Sound fader control (front/rear) down to -30 dB in steps of 2 dB
- Fast muting via bus or via setting the muting pin
- Suitable for external audio equalizers, can be looped-in controlled by the I²C-bus
- Power-on reset on chip sets the device into general mute position
- AC and DC short-circuit protected concerning neighbouring pins
- I²C-bus control for all functions.



GENERAL DESCRIPTION

This bipolar IC is an I²C-bus controlled sound/volume controller for car radios, in addition with fader function and the possibility of an external equalizer.

QUICK REFERENCE DATA

SYMBOL	PARAMETER	MIN.	TYP.	MAX.	UNIT
V _P	supply voltage	7	8.5	10	V
I _P	supply current	–	26	–	mA
V _i	maximum AF input signal (RMS value)	2	–	–	V
V _o	maximum AF output signal (RMS value)	1.1	–	–	V
ΔG _v	volume control range, separated	–66	–	+20	dB
	fader control range, separated	0	–	–30	dB
	bass control range	–12	–	+15	dB
	treble control range	–12	–	+12	dB
THD	total harmonic distortion	–	–	0.2	%
S/N(W)	weighted signal-to-noise ratio	–	67	–	dB
α _{CR}	crosstalk attenuation	–	90	–	dB
B	frequency response (–1 dB)	–	35 to 20000	–	Hz

ORDERING INFORMATION

EXTENDED TYPE NUMBER	PACKAGE			
	PINS	PIN POSITION	MATERIAL	CODE
TEA6330T ⁽¹⁾	20	SO	plastic	SOT163A

Note

1. Plastic small outline package; 20 leads; body width 7.5 mm; (SOT163A); SOT163-1; 1996 August 02.

Sound fader control circuit
for car radios

TEA6330T

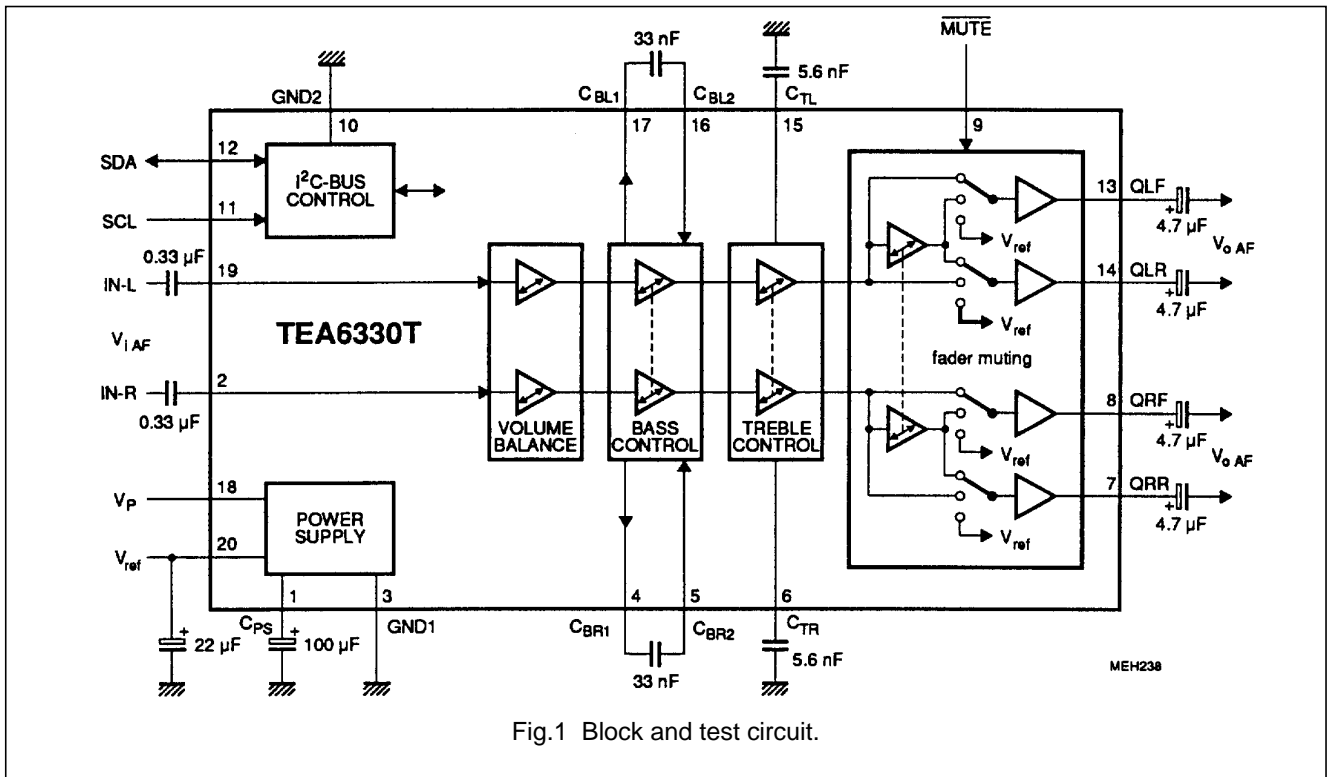

Fig.1 Block and test circuit.

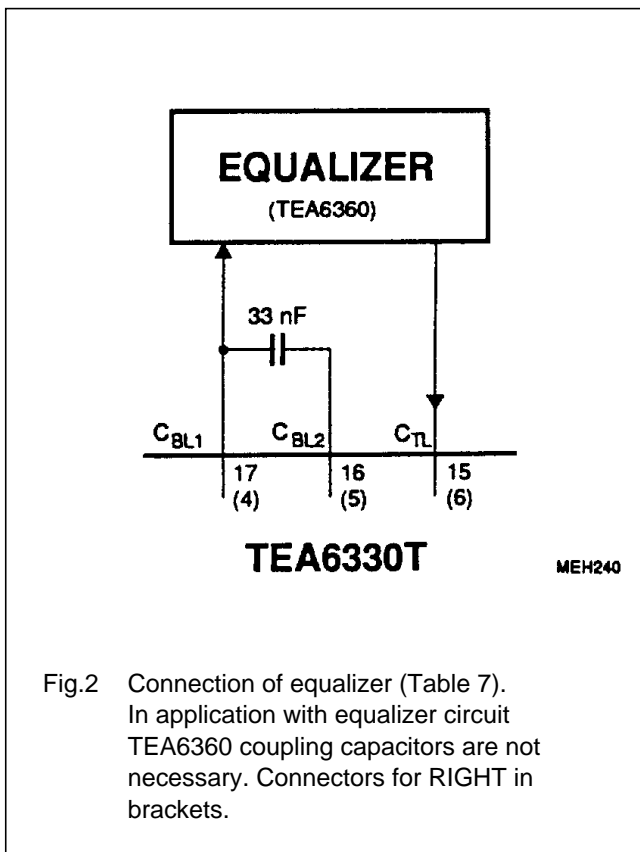

Fig.2 Connection of equalizer (Table 7).
In application with equalizer circuit
TEA6360 coupling capacitors are not
necessary. Connectors for RIGHT in
brackets.

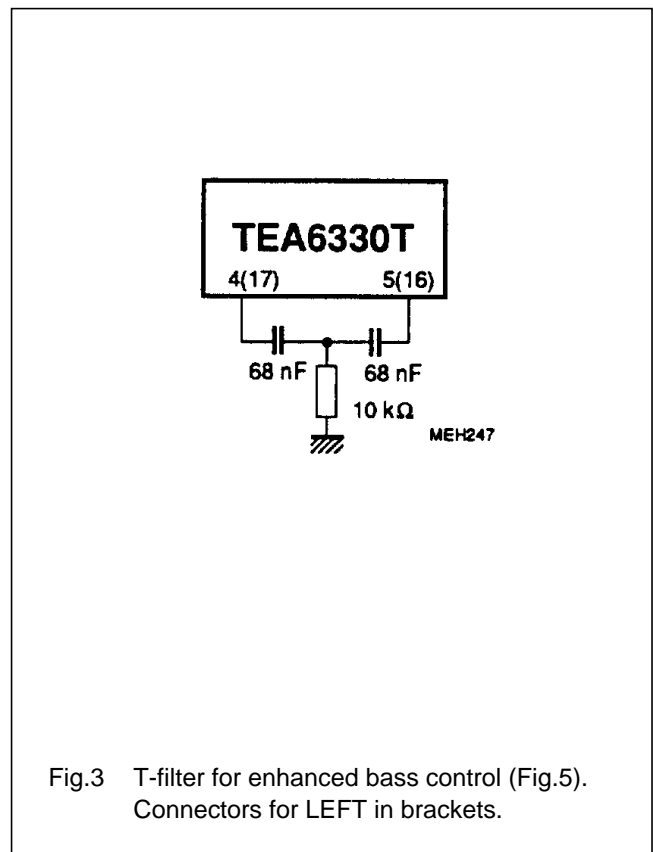

Fig.3 T-filter for enhanced bass control (Fig.5).
Connectors for LEFT in brackets.

Sound fader control circuit for car radios

TEA6330T

PINNING

SYMBOL	PIN	DESCRIPTION
C _{PS}	1	filtering capacitor for power supply
IN-R	2	audio input signal RIGHT
GND1	3	analog ground (0 V)
C _{BR1}	4	capacitor for bass control RIGHT and signal to equalizer
C _{BR2}	5	capacitor for bass control RIGHT
C _{TR}	6	capacitor for treble control RIGHT, input signal for equalizer RIGHT
QRR	7	right audio output signal of rear channel
QRF	8	right audio output signal of front channel
MUTE	9	input to set mute externally
GND2	10	digital ground (0 V) for bus control
SCL	11	clock signal of I ² C-bus
SDA	12	data signal of I ² C-bus
QLF	13	left audio output signal of front channel
QLR	14	left audio output signal of rear channel
C _{TL}	15	capacitor for treble control LEFT, input signal for equalizer LEFT
C _{BL2}	16	capacitor for bass control LEFT
C _{BL1}	17	capacitor for bass control LEFT and signal to equalizer
V _P	18	+8.5 V supply voltage
IN-L	19	audio input signal LEFT
V _{ref}	20	reference voltage output (V _P /2)

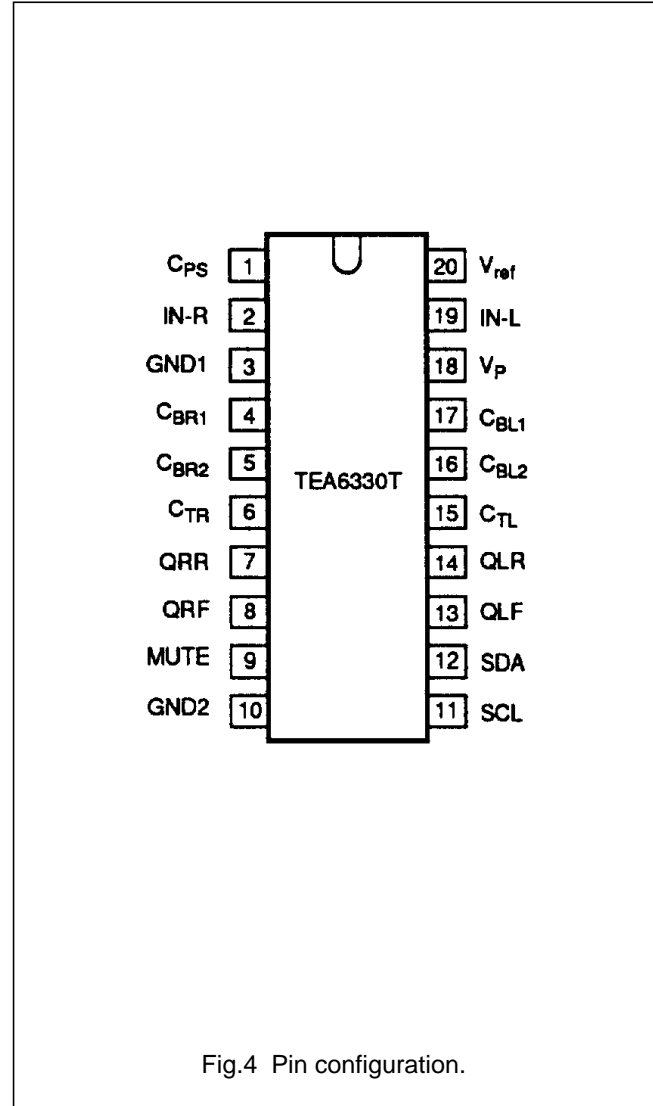

Sound fader control circuit for car radios

TEA6330T

FUNCTIONAL DESCRIPTION

This bipolar IC is an I²C-bus controlled sound/volume controller for car radios including fader function and the possibility of an external equalizer. The sound signal setting is performed by resistor chains in combination with multi-input operational amplifiers. The advantages of this principle are the combination of low noise, low distortion and a high dynamic range. The separated volume controls of the left and the right channel make the balance control possible. The value and the characteristic of the balance is controlled via the I²C-bus.

The contour function is performed by setting an extra bass control and optional treble, depending on the actual volume position. Its switching points and its range are also controllable via the I²C-bus.

An interface is assigned behind the volume control to loop-in an equalizer (Fig.2). In this case the treble control is switched off, and the bass control can be used to set the contour.

Low level control fader is included independent of the volume controls, because the TEA6330T has four driver outputs (for front and rear).

An extra mute position for the front, the rear or for all channels is built in. The last function may be used for muting during preset selection. No external interface is required between the microcomputer and this circuit, for all switching and controlling functions are controllable via the two-wire I²C-bus.

The separate mute-pin allows to switch the fader into mute position without using the I²C-bus.

The on chip power-on reset sets the TEA6330T into the general mute mode.

LIMITING VALUES

In accordance with the Absolute Maximum System (IEC 134). Ground pins 3 and 10 connected together.

SYMBOL	PARAMETER	MIN.	MAX.	UNIT
V _P	supply voltage (pin 18)	0	10	V
P _{tot}	total power dissipation	0	700	mW
T _{stg}	storage temperature range	-55	150	°C
T _{amb}	operating ambient temperature range	-40	85	°C
V _{ESD}	electrostatic handling* for all pins	-	±300	V
	electrostatic handling** for all pins	-	±4000	V

* Equivalent to discharging a 200 pF capacitor through a 0 Ω series resistor.

** Equivalent to discharging a 100 pF capacitor through a 1.5 kΩ series resistor.

Sound fader control circuit for car radios

TEA6330T

CHARACTERISTICS

$V_P = 8.5$ V; load resistors at audio outputs 10 k Ω , $f_i = 1$ kHz ($R_S = 600$ Ω), bass and treble in linear position, fader in off position and $T_{amb} = 25$ °C; measurements taken in Fig.1 unless otherwise specified.

SYMBOL	PARAMETER	CONDITIONS	MIN.	TYP.	MAX.	UNIT
V_P	supply voltage range (pin 18)		7	8.5	10	V
I_P	supply current		–	26	–	mA
V_{ref}	reference voltage (pin 20)		$0.45 V_P$	$0.5 V_P$	$0.55 V_P$	V
V_O	DC voltage at output (pins 7, 8, 13, 14)		–	$0.5 V_P$	–	V
Measurements over all						
V_i	maximum AF input level for THD = 2 % at pins 2 and 19 (RMS value)	$G_V = -66$ to -6 dB and $V_P = 8.1$ V	2	–	–	V
V_o	maximum AF output level for THD = 2% at pins 7, 8, 13, 14 (RMS value)	$G_V = -4$ to $+20$ dB and $V_P = 8.1$ V	1.1	–	–	V
G_V	maximum gain by volume setting		19	20	21	dB
B	frequency response	-1 dB roll-off frequency	–	35 to 20000	–	Hz
α_{CR}	crosstalk attenuation	$f = 250$ to 10000 Hz $G_V = 0$ dB	70	90	–	dB
THD	total harmonic distortion $V_i (RMS) = 50$ mV $V_i (RMS) = 500$ mV $V_i (RMS) = 1.6$ V	$f = 20$ to 12500 Hz $G_V = +20$ dB $G_V = 0$ dB $G_V = -10$ dB	– – –	0.1 0.05 0.2	0.3 0.2 0.5	% % %
RR	ripple rejection for $V_R < 200$ mV RMS	$G_V = 0$ dB $f = 100$ Hz $f = 40$ Hz to 3 kHz $f = 3$ to 12.5 kHz	– – –	70 60 50	– – –	dB dB dB
P_N	noise power at output of a 25 W powerstage with 26 dB gain (only contribution of TEA6330T)	mute position ($V_g = 0$)	–	–	10	nW
α_{BUS}	crosstalk attenuation between SDA, SCL and signal output ($20 \log V_{BUS} (p-p)/V_o$ RMS)	$G_V = 0$ dB	–	110	–	dB
S/N(W)	weighted signal-to-noise ratio for $V_i = 50$ mV RMS $V_i = 500$ mV RMS $V_i = 50$ mV RMS $V_i = 500$ mV RMS $V_i = 50$ mV RMS $V_i = 500$ mV RMS	CCIR 468-2 quasi peak for 6 W power amplifier $P_o = 50$ mW $P_o = 50$ mW $P_o = 1$ W $P_o = 1$ W $P_o = 6$ W; Fig.9 $P_o = 6$ W; Fig.9	– – 65 71 – –	65 67 72 78 72 86	– – – – – –	dB dB dB dB dB dB

Sound fader control circuit for car radios

TEA6330T

SYMBOL	PARAMETER	CONDITIONS	MIN.	TYP.	MAX.	UNIT
Audio frequency outputs QLF, QRF, QLR and QRR						
V_o	maximum output signal (RMS value)		1.1	–	–	V
R_o	output resistance (pins 7, 8, 13 and 14)		–	100	150	Ω
R_L	admissible output load resistor	to ground or V_{CC}	7.5	–	–	k Ω
C_L	admissible output load capacitor		–	–	2.5	nF
$V_{N(W)}$	weighted noise voltage at output	CCIR 468-2 ; Fig.8 quasi peak				
	for maximum gain	$G_V = +20$ dB	–	110	220	μ V
	for 0 dB gain	$G_V = 0$ dB	–	25	50	μ V
	for minimum gain	$G_V = -66$ dB	–	19	38	μ V
	for mute position	($V_g = 0$)	–	11	22	μ V
Volume control		$R_G = 600\Omega$				
R_I	input resistance (pins 2 and 19)		35	50	65	k Ω
G_V	volume control range	Table 2	-66	–	+20	dB
ΔG_V	step width		–	2	-	dB
	gain set error	$G_V = -50$ to +20 dB	–	–	2	dB
		$G_V = -66$ to -50 dB	–	–	3	dB
	gain tracking error	balance in mid position	–	–	2	dB
α_{mute}	mute attenuation at volume mute	set mute-bits	76	90	–	dB
Bass control						
G_V	controllable bass range	Table 3; Fig.6				
	maximum boost	f = 40 Hz	14	15	16	dB
	maximum boost	f = 100 Hz	12	13	14	dB
	maximum attenuation	f = 40 Hz	11	12	13	dB
	maximum attenuation	f = 100 Hz	10	11	12	dB
ΔG_V	step width	f = 40 Hz	2.5	3	3.5	dB
Treble control						
G_V	controllable treble range	Table 4; Fig.7				
	maximum boost	f = 10 kHz	9	10	11	dB
	maximum boost	f = 15 kHz	11	12	13	dB
	maximum boost	f > 15 kHz	–	–	15	dB
	maximum attenuation	f = 10 kHz	9	10	11	dB
	maximum attenuation	f = 15 kHz	11	12	13	dB
ΔG_V	step width	f = 15 kHz	2.5	3	3.5	dB

Sound fader control circuit for car radios

TEA6330T

SYMBOL	PARAMETER	CONDITIONS	MIN.	TYP.	MAX.	UNIT
Fader control						
G_V	fader control range	Table 5	–	0 to –30	–	dB
	step width		1.5	2	2.5	dB
α_{MUTE}	mute attenuation	GMB-bit = 1; Table 6	74	84	–	dB
ΔV_o	DC offset output voltage (pins 7, 8, 13, 14) between any adjoining volume step and any step to mute	$G_V = -66$ to 0 dB	–	0.2	10	mV
		$G_V = 0$ to +20 dB	–	2	15	mV
	in any treble and fader position	$G_V = -66$ to 0 dB	–	–	10	mV
	in any bass position	$G_V = -66$ to 0 dB	–	–	10	mV
External mute (pin 9)						
V_9	input voltage for MUTE-ON (LOW)	fader is switched into general mute position	0	–	1.5	V
	input voltage for MUTE-OFF (HIGH)	Tables 2 and 5	3	–	V_P	V
	input voltage for MUTE-OFF	pin 9 open-circuit	–	5	–	V
I_9	input current		–	–	± 10	μA
I²C-bus, SCL and SDA (pins 11 and 12)						
$V_{11, 12}$	input voltage HIGH-level		3	–	V_P	V
	input voltage LOW-level		0	–	1.5	V
$I_{11, 12}$	input current		–	–	± 10	μA
V_{ACK}	output voltage at acknowledge (pin 12)	$I_{12} = -3$ mA	–	–	0.4	V
Power-on reset, when reset is active the GMU-bit (general mute) is set and the bus receiver is in reset position						
V_P	supply voltage for start of reset	increasing voltage	–	–	2.5	V
	supply voltage for end of reset	increasing voltage	5.2	6.0	6.8	V
	supply voltage for start of reset	decreasing voltage	4.2	5.0	5.8	V

Sound fader control circuit for car radios

TEA6330T

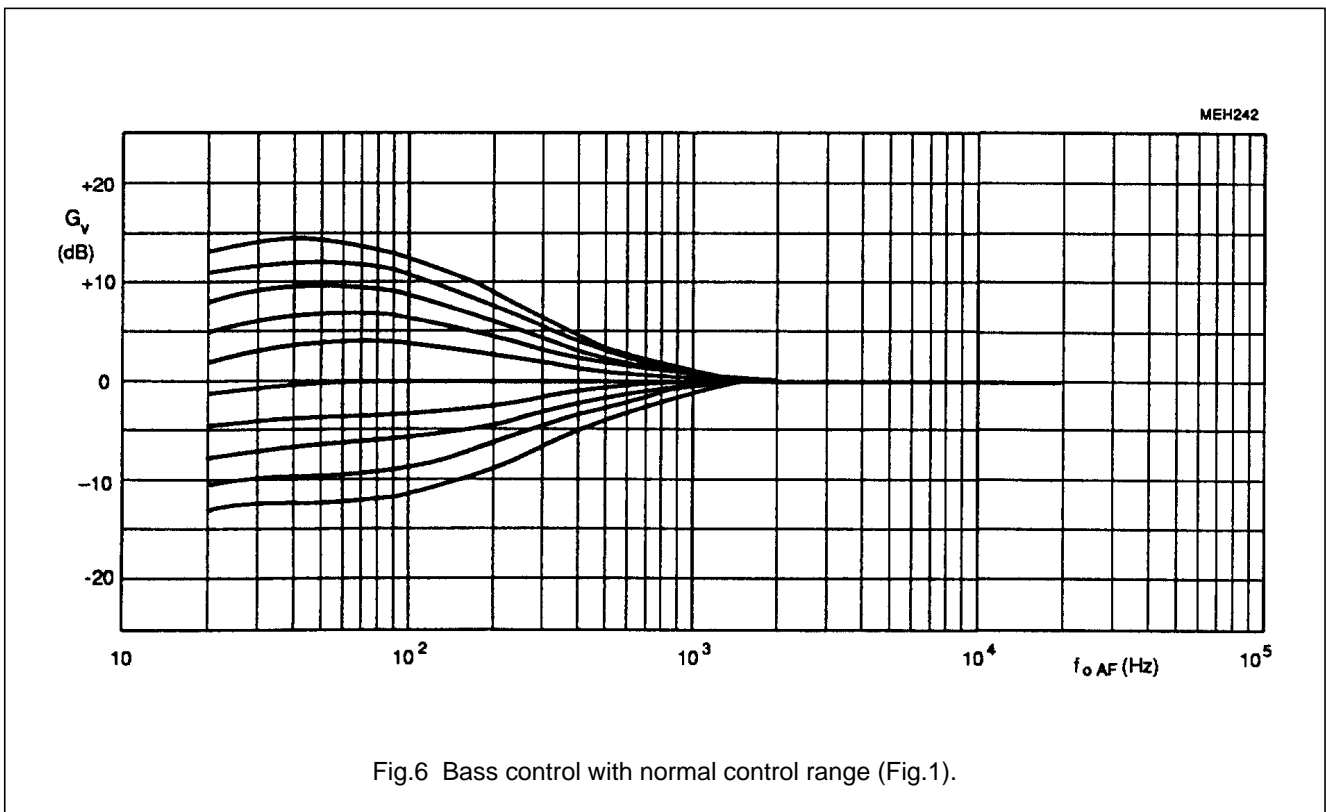
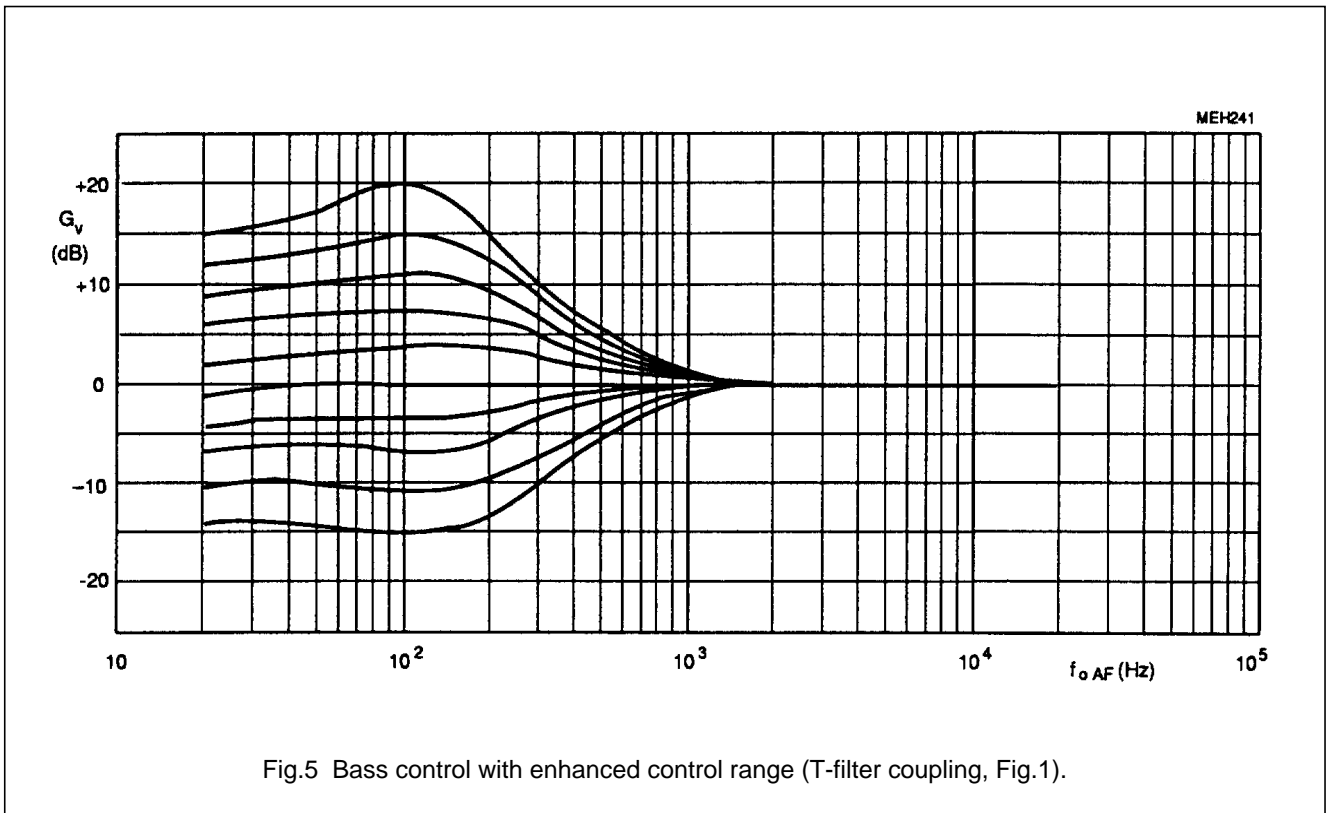

Sound fader control circuit
for car radios

TEA6330T

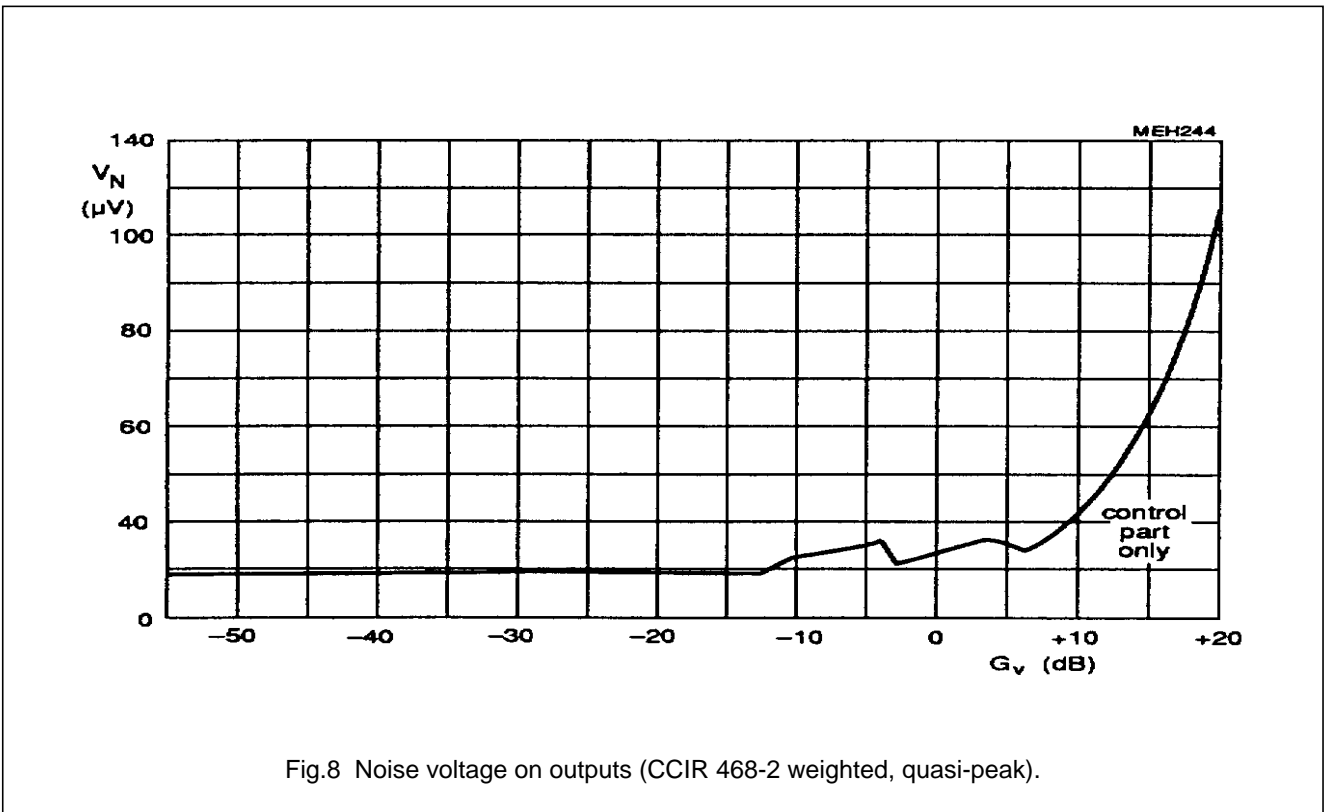
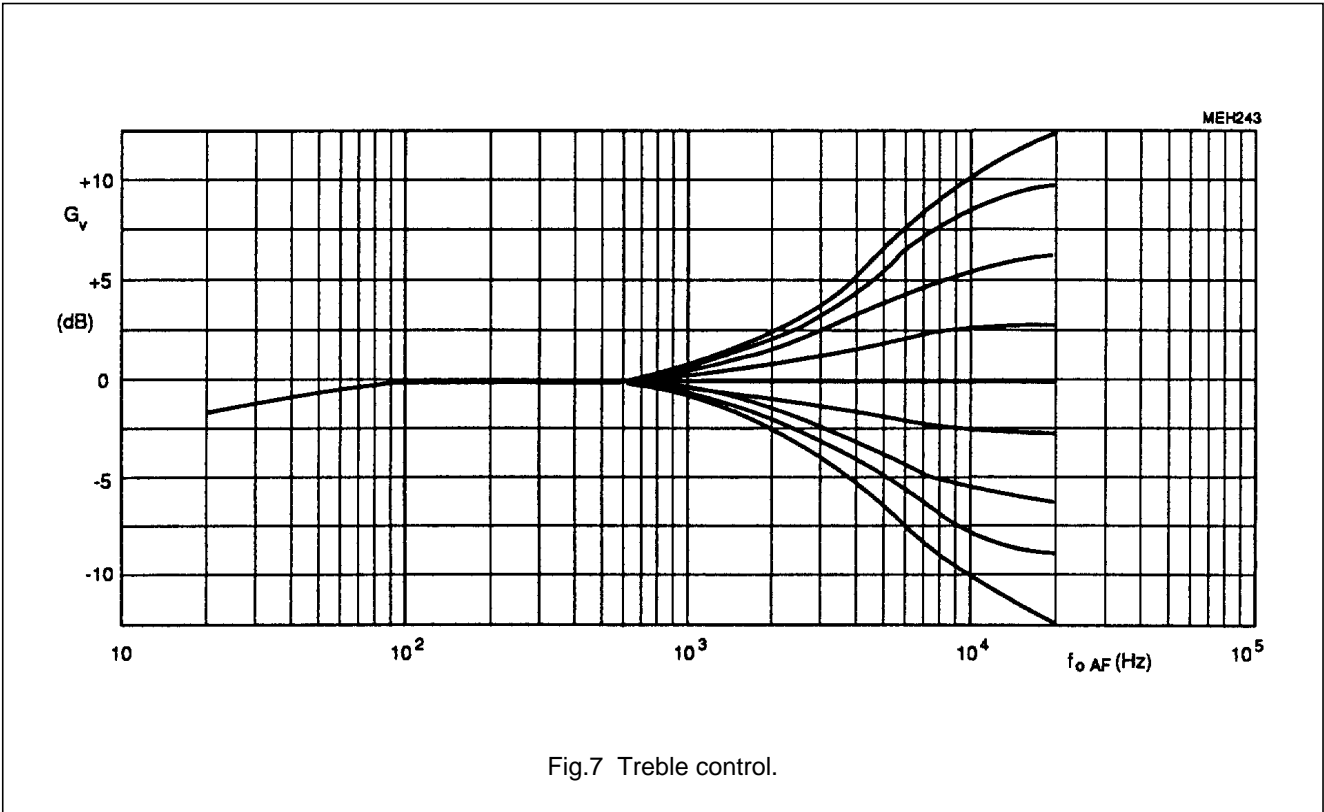

Sound fader control circuit for car radios

TEA6330T

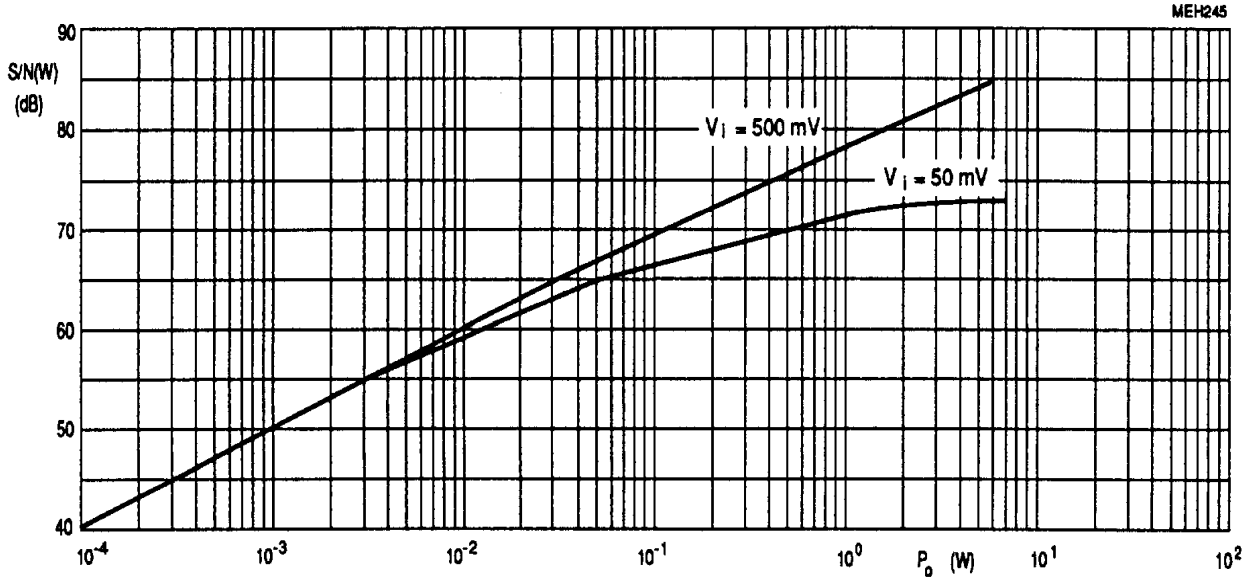

Fig.9 Signal-to-noise ratio (CCIR 468-2 weighted, quasi-peak) for TEA6330T with a 6 W power amplifier (20 dB gain, Fig.10). Measurements without noise contribution of the power amplifier.

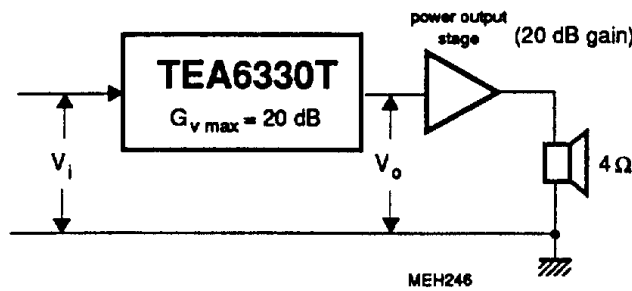

Fig.10 Signal-to-noise ratio measurement (Fig.9) with $V_i = 50$ mV RMS, $V_o = 500$ mV RMS for $P_{max} = 6$ W.

Sound fader control circuit
for car radios

TEA6330T

I²C-BUS PROTOCOL

I²C-bus format

S	SLAVE ADDRESS	A	SUBADDRESS	A	DATA	P
----------	----------------------	----------	-------------------	----------	-------------	----------

- S = start condition
- SLAVE ADDRESS = **1000 000X**
- A = acknowledge, generated by the slave
- SUBADDRESS = subaddress byte, Table 1
- DATA = data byte, Table 1
- P = stop condition
- X = read/write control bit
X = 0, order to write (the circuit is slave receiver only)

If more than 1 byte DATA are transmitted, then auto-increment of the subaddress is performed.

Byte organisation

Table 1 I²C-bus transmission

FUNCTION	SUBADDRESS BYTE								DATA BYTE							
									D7	D6	D5	D4	D3	D2	D1	D0
volume left	0	0	0	0	0	0	0	0	0	0	VL5	VL4	VL3	VL2	VL1	VL0
volume right	0	0	0	0	0	0	0	1	0	0	VR5	VR4	VR3	VR2	VR1	VR0
bass	0	0	0	0	0	0	1	0	0	0	0	0	BA3	BA2	BA1	BA0
treble	0	0	0	0	0	0	1	1	0	0	0	0	TR3	TR2	TR1	TR0
fader	0	0	0	0	0	1	0	0	0	0	MFN	FCH	FA3	FA2	FA1	FA0
audio switch	0	0	0	0	0	1	0	1	GMU	EQN	0	0	0	0	0	0

Function of the bits:

- VL0 to VL5 volume control of left channel (balance control)
- VR0 to VR5 volume control of right channel (balance control)
- BA0 to BA3 bass control of both channels
- TRO to TR3 treble control of both channels
- FA0 to FA3 fader control front to rear

- FCH select fader channels front or rear
- MFN mute control of the selected channels front or rear
- GMU mute control, general mute
- EQN equalizer switchover (0 = equalizer-on)

Sound fader control circuit for car radios

TEA6330T

Table 2(a) Volume setting LEFT

G _V DB	DATA						G _V DB	DATA					
	VL5	VL4	VL3	VL2	VL1	VL0		VL5	VL4	VL3	VL2	VL1	VL0
+20	1	1	1	1	1	1	-32	1	0	0	1	0	1
+18	1	1	1	1	1	0	-34	1	0	0	1	0	0
+16	1	1	1	1	0	1	-36	1	0	0	0	1	1
+14	1	1	1	1	0	0	-38	1	0	0	0	1	0
+12	1	1	1	0	1	1	-40	1	0	0	0	0	1
+10	1	1	1	0	1	0	-42	1	0	0	0	0	0
+8	1	1	1	0	0	1	-44	0	1	1	1	1	1
+6	1	1	1	0	0	0	-46	0	1	1	1	1	0
+4	1	1	0	1	1	1	-48	0	1	1	1	0	1
+2	1	1	0	1	1	0	-50	0	1	1	1	0	0
0	1	1	0	1	0	1	-52	0	1	1	0	1	1
-2	1	1	0	1	0	0	-54	0	1	1	0	1	0
-4	1	1	0	0	1	1	-56	0	1	1	0	0	1
-6	1	1	0	0	1	0	-58	0	1	1	0	0	0
-8	1	1	0	0	0	1	-60	0	1	0	1	1	1
-10	1	1	0	0	0	0	-62	0	1	0	1	1	0
-12	1	0	1	1	1	1	-64	0	1	0	1	0	1
-14	1	0	1	1	1	0	-66	0	1	0	1	0	0
-16	1	0	1	1	0	1	mute	0	1	0	0	1	1
-18	1	0	1	1	0	0	left						
-20	1	0	1	0	1	1	mute	0	1	0	0	1	0
-22	1	0	1	0	1	0	left						
-24	1	0	1	0	0	1	---			---			---
-26	1	0	1	0	0	0	---			---			---
-28	1	0	0	1	1	1	---			---			---
-30	1	0	0	1	1	0	mute	0	0	0	0	0	0
							left						

Sound fader control circuit for car radios

TEA6330T

Table 2(b) Volume setting RIGHT

G _V DB	DATA						G _V DB	DATA					
	VR5	VR4	VR3	VR2	VR1	VL0		VR5	VR4	VR3	VR2	VR1	VL0
+20	1	1	1	1	1	1	-32	1	0	0	1	0	1
+18	1	1	1	1	1	0	-34	1	0	0	1	0	0
+16	1	1	1	1	0	1	-36	1	0	0	0	1	1
+14	1	1	1	1	0	0	-38	1	0	0	0	1	0
+12	1	1	1	0	1	1	-40	1	0	0	0	0	1
+10	1	1	1	0	1	0	-42	1	0	0	0	0	0
+8	1	1	1	0	0	1	-44	0	1	1	1	1	1
+6	1	1	1	0	0	0	-46	0	1	1	1	1	0
+4	1	1	0	1	1	1	-48	0	1	1	1	0	1
+2	1	1	0	1	1	0	-50	0	1	1	1	0	0
0	1	1	0	1	0	1	-52	0	1	1	0	1	1
-2	1	1	0	1	0	0	-54	0	1	1	0	1	0
-4	1	1	0	0	1	1	-56	0	1	1	0	0	1
-6	1	1	0	0	1	0	-58	0	1	1	0	0	0
-8	1	1	0	0	0	1	-60	0	1	0	1	1	1
-10	1	1	0	0	0	0	-62	0	1	0	1	1	0
-12	1	0	1	1	1	1	-64	0	1	0	1	0	1
-14	1	0	1	1	1	0	-66	0	1	0	1	0	0
-16	1	0	1	1	0	1	mute right	0	1	0	0	1	1
-18	1	0	1	1	0	0	mute right	0	1	0	0	1	0
-20	1	0	1	0	1	1	---			---		---	
-22	1	0	1	0	1	0	---			---		---	
-24	1	0	1	0	0	1	---			---		---	
-26	1	0	1	0	0	0	mute right	0	0	0	0	0	0
-28	1	0	0	1	1	1							
-30	1	0	0	1	1	0							

Sound fader control circuit
for car radios

TEA6330T

Table 3(a)
Bass setting with equalizer passive (EQN = 1)

G _V DB	DATA			
	D3	D2	D1	D0
+15	1	1	1	1
+15	1	1	1	0
+15	1	1	0	1
+15	1	1	0	0
+12	1	0	1	1
+9	1	0	1	0
+6	1	0	0	1
+3	1	0	0	0
0	0	1	1	1
-3	0	1	1	0
-6	0	1	0	1
-9	0	1	0	0
-12	0	0	1	1
-12	0	0	1	0
-12	0	0	0	0

Table 3(b)
Bass setting with equalizer active (EQN = 0)

G _V DB	DATA			
	D3	D2	D1	D0
+15	1	1	1	1
+15	1	1	1	0
+15	1	1	0	1
+15	1	1	0	0
+12	1	0	1	1
+9	1	0	1	0
+6	1	0	0	1
+3	1	0	0	0
0	0	1	1	1
0	0	1	1	0
0	0	1	0	1
0	0	1	0	0
0	0	0	1	1
0	0	0	1	0
0	0	0	0	0

Table 4(a)
Treble setting with equalizer passive (EQN = 1)

G _V DB	DATA			
	D3	D2	D1	D0
+12	1	1	1	1
+12	1	1	1	0
+12	1	1	0	1
+12	1	1	0	0
+12	1	0	1	1
+9	1	0	1	0
+6	1	0	0	1
+3	1	0	0	0
0	0	1	1	1
-3	0	1	1	0
-6	0	1	0	1
-9	0	1	0	0
-12	0	0	1	1
-12	0	0	1	0
-12	0	0	0	0

Table 4(b)
Treble setting with equalizer active (EQN = 0)

G _V DB	DATA			
	D3	D2	D1	D0
0	1	1	1	1
0	1	1	1	0
0	1	1	0	1
0	1	1	0	0
0	1	0	1	1
0	1	0	1	0
0	1	0	0	1
0	1	0	0	0
0	0	1	1	1
0	0	1	1	0
0	0	1	0	1
0	0	1	0	0
0	0	0	1	1
0	0	0	1	0
0	0	0	0	0

Sound fader control circuit
for car radios

TEA6330T

Table 5(a) Fader function front

SETTING		DATA					
FRONT	REAR	MFN	FCH	FA3	FA2	FA1	FA0
DB	DB						
		fader-off					
0	0	1	1	1	1	1	1
0	0	0	1	1	1	1	1
		fader-front					
-2	0	1	1	1	1	1	0
-4	0	1	1	1	1	0	1
-6	0	1	1	1	1	0	0
-8	0	1	1	1	0	1	1
-10	0	1	1	1	0	1	0
-12	0	1	1	1	0	0	1
-14	0	1	1	1	0	0	0
-16	0	1	1	0	1	1	1
-18	0	1	1	0	1	1	0
-20	0	1	1	0	1	0	1
-22	0	1	1	0	1	0	0
-24	0	1	1	0	0	1	1
-26	0	1	1	0	0	1	0
-28	0	1	1	0	0	0	1
-30	0	1	1	0	0	0	0
		mute front					
-84	0	0	1	1	1	1	0
---				---			---
---				---			---
---				---			---
-84	0	0	1	0	0	0	0

Table 5(b) Fader function rear

SETTING		DATA					
FRONT	REAR	MFN	FCH	FA3	FA2	FA1	FA0
DB	DB						
		fader-off					
0	0	1	0	1	1	1	1
0	0	0	0	1	1	1	1
		fader rear					
0	-2	1	0	1	1	1	0
0	-4	1	0	1	1	0	1
0	-6	1	0	1	1	0	0
0	-8	1	0	1	0	1	1
0	-10	1	0	1	0	1	0
0	-12	1	0	1	0	0	1
0	-14	1	0	1	0	0	0
0	-16	1	0	0	1	1	1
0	-18	1	0	0	1	1	0
0	-20	1	0	0	1	0	1
0	-22	1	0	0	1	0	0
0	-24	1	0	0	0	1	1
0	-26	1	0	0	0	1	0
0	-28	1	0	0	0	0	1
0	-30	1	0	0	0	0	0
		mute rear					
0	-84	0	0	1	1	1	0
	---			---			---
	---			---			---
	---			---			---
0	-84	0	0	0	0	0	0

Table 6 Mute control

MUTE CONTROL	DATA GMU-BIT	REMARKS
active	1	outputs QLF, QLR, QRF and QRR are muted
passive	0	no general mute

Table 7 Equalizer

EQUALIZER CONTROL	DATA EQN-BIT	REMARKS
active	0	signal outputs for equalizer are pins 4 and 17, inputs are pins 6 and 15; Tables 3(b) and 4(b)
passive	1	no general mute; Tables 3(a) and 4(a)

Sound fader control circuit
for car radios

TEA6330T

PACKAGE OUTLINE

SO20: plastic small outline package; 20 leads; body width 7.5 mm

SOT163-1

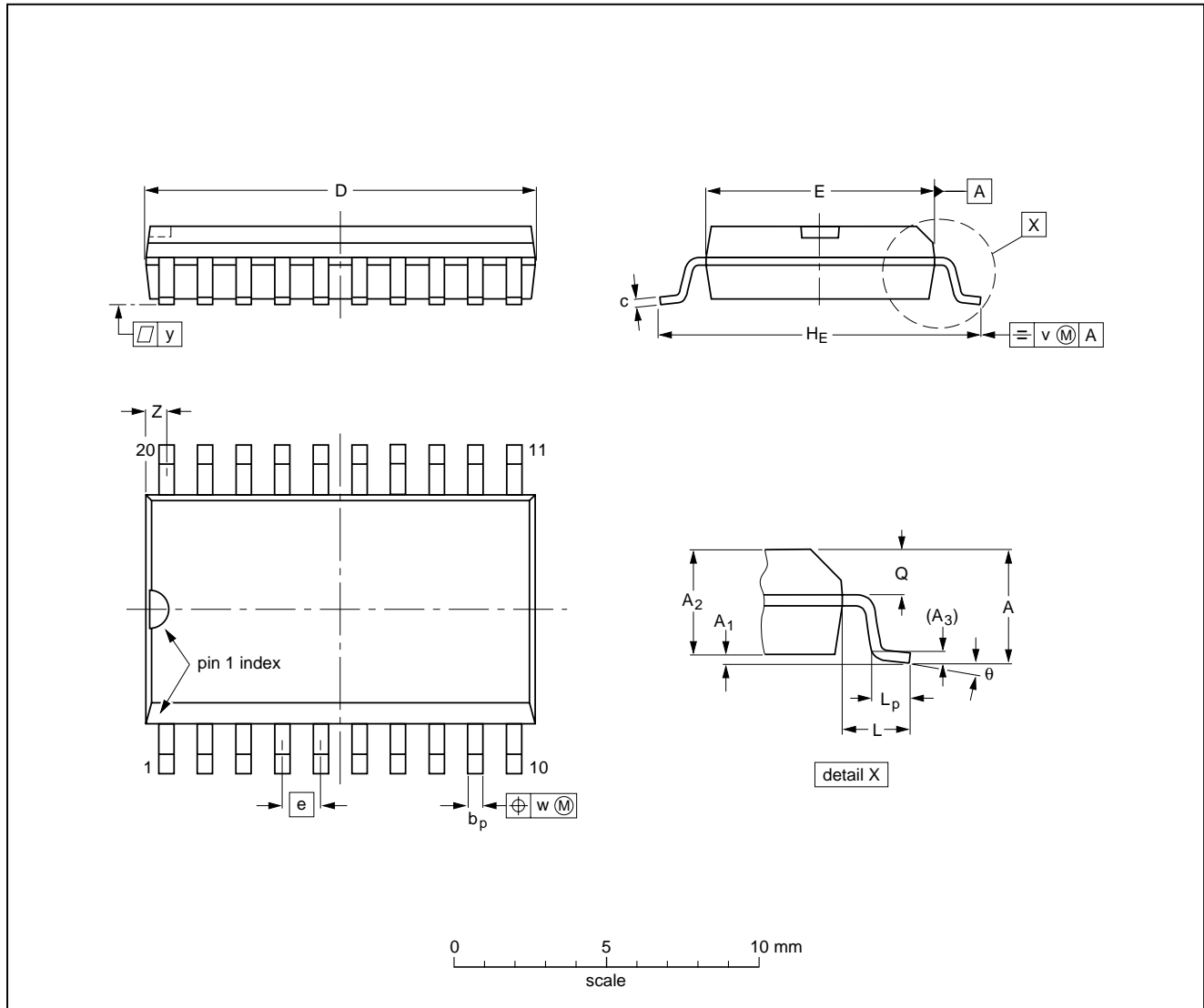

DIMENSIONS (inch dimensions are derived from the original mm dimensions)

UNIT	A max.	A ₁	A ₂	A ₃	b _p	c	D ⁽¹⁾	E ⁽¹⁾	e	H _E	L	L _p	Q	v	w	y	z ⁽¹⁾	θ
mm	2.65	0.30 0.10	2.45 2.25	0.25	0.49 0.36	0.32 0.23	13.0 12.6	7.6 7.4	1.27	10.65 10.00	1.4	1.1 0.4	1.1 1.0	0.25	0.25	0.1	0.9 0.4	8° 0°
inches	0.10	0.012 0.004	0.096 0.089	0.01	0.019 0.014	0.013 0.009	0.51 0.49	0.30 0.29	0.050	0.419 0.394	0.055	0.043 0.016	0.043 0.039	0.01	0.01	0.004	0.035 0.016	

Note

1. Plastic or metal protrusions of 0.15 mm maximum per side are not included.

OUTLINE VERSION	REFERENCES				EUROPEAN PROJECTION	ISSUE DATE
	IEC	JEDEC	EIAJ			
SOT163-1	075E04	MS-013AC				95-01-24 97-05-22

Sound fader control circuit for car radios

TEA6330T

SOLDERING

Introduction

There is no soldering method that is ideal for all IC packages. Wave soldering is often preferred when through-hole and surface mounted components are mixed on one printed-circuit board. However, wave soldering is not always suitable for surface mounted ICs, or for printed-circuits with high population densities. In these situations reflow soldering is often used.

This text gives a very brief insight to a complex technology. A more in-depth account of soldering ICs can be found in our "*IC Package Databook*" (order code 9398 652 90011).

Reflow soldering

Reflow soldering techniques are suitable for all SO packages.

Reflow soldering requires solder paste (a suspension of fine solder particles, flux and binding agent) to be applied to the printed-circuit board by screen printing, stencilling or pressure-syringe dispensing before package placement.

Several techniques exist for reflowing; for example, thermal conduction by heated belt. Dwell times vary between 50 and 300 seconds depending on heating method. Typical reflow temperatures range from 215 to 250 °C.

Preheating is necessary to dry the paste and evaporate the binding agent. Preheating duration: 45 minutes at 45 °C.

Wave soldering

Wave soldering techniques can be used for all SO packages if the following conditions are observed:

- A double-wave (a turbulent wave with high upward pressure followed by a smooth laminar wave) soldering technique should be used.
- The longitudinal axis of the package footprint must be parallel to the solder flow.
- The package footprint must incorporate solder thieves at the downstream end.

During placement and before soldering, the package must be fixed with a droplet of adhesive. The adhesive can be applied by screen printing, pin transfer or syringe dispensing. The package can be soldered after the adhesive is cured.

Maximum permissible solder temperature is 260 °C, and maximum duration of package immersion in solder is 10 seconds, if cooled to less than 150 °C within 6 seconds. Typical dwell time is 4 seconds at 250 °C.

A mildly-activated flux will eliminate the need for removal of corrosive residues in most applications.

Repairing soldered joints

Fix the component by first soldering two diagonally-opposite end leads. Use only a low voltage soldering iron (less than 24 V) applied to the flat part of the lead. Contact time must be limited to 10 seconds at up to 300 °C. When using a dedicated tool, all other leads can be soldered in one operation within 2 to 5 seconds between 270 and 320 °C.

Sound fader control circuit for car radios

TEA6330T

DEFINITIONS

Data sheet status	
Objective specification	This data sheet contains target or goal specifications for product development.
Preliminary specification	This data sheet contains preliminary data; supplementary data may be published later.
Product specification	This data sheet contains final product specifications.
Limiting values	
Limiting values given are in accordance with the Absolute Maximum Rating System (IEC 134). Stress above one or more of the limiting values may cause permanent damage to the device. These are stress ratings only and operation of the device at these or at any other conditions above those given in the Characteristics sections of the specification is not implied. Exposure to limiting values for extended periods may affect device reliability.	
Application information	
Where application information is given, it is advisory and does not form part of the specification.	

LIFE SUPPORT APPLICATIONS

These products are not designed for use in life support appliances, devices, or systems where malfunction of these products can reasonably be expected to result in personal injury. Philips customers using or selling these products for use in such applications do so at their own risk and agree to fully indemnify Philips for any damages resulting from such improper use or sale.

Copyright © Each Manufacturing Company.

All Datasheets cannot be modified without permission.

This datasheet has been download from :

www.AllDataSheet.com

100% Free DataSheet Search Site.

Free Download.

No Register.

Fast Search System.

www.AllDataSheet.com